

# KINTEK®

## INSPECTION GAUGES

### ELEMENTI DI CONTROLLO



04



**INSPECTION GAUGES** 

ELEMENTI DI CONTROLLO 

MESSTECHNIK 

EQUIPEMENTS DE CONTRÔLE 

ПРИБОРЫ КОНТРОЛЯ 

检控元件 

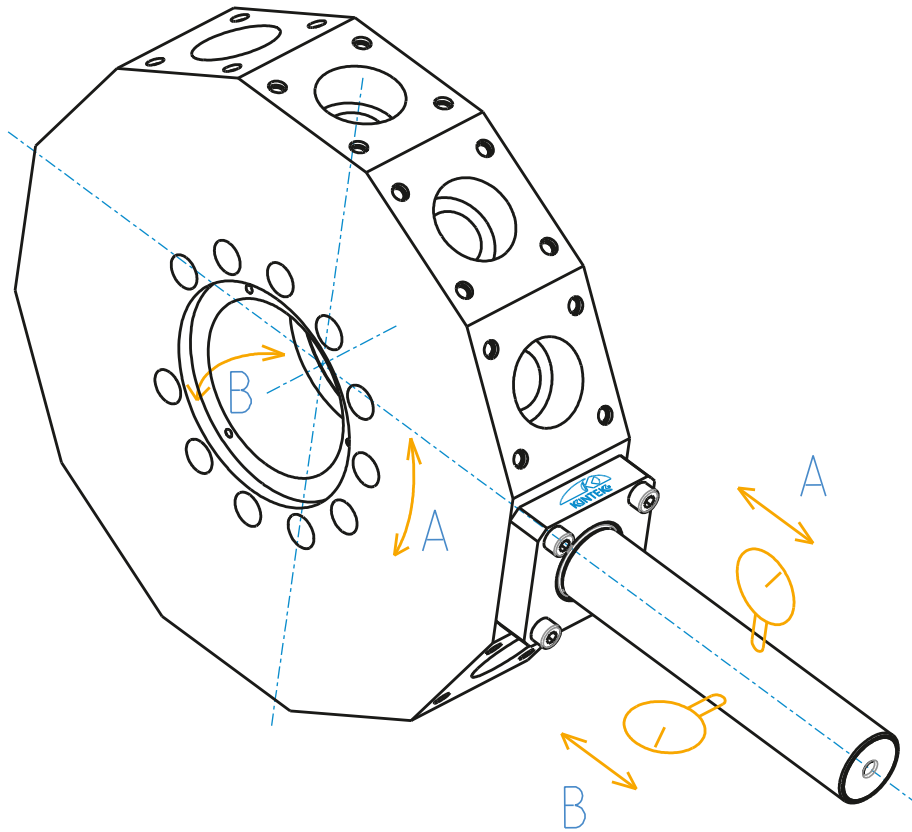

04



- Control pin for CNC lathes turret with test certificate included.
- Radial runout/ attachment precision, contact face and control cylinder within 0,003  $\mu$ .
- Application: after having set it up in any turret station like a normal tool holder, you can check its orthogonality by moving the dial indicator along the X axis of the machine.



- Barra di controllo per disco portautensili per torni CNC con certificato di controllo allegato.
- Eccentricità / Precisione per attacco, facciata di contatto e cilindro di controllo entro 0,003  $\mu$ .
- Sistema d'impiego: dopo averla montata come un normale portautensile in una stazione a scelta, si può controllare l'ortogonalità della stessa facendo scorrere un indicatore millesimale lungo l'asse X della macchina.



- Prüfdorne für CNC-Drehmaschinenrevolver inklusiv des Messprotokolls.
- Exzentrizität / Aufnahmepräzision, Kontaktfläche und Kontrollzylinder innerhalb 0,003  $\mu$ .
- Anwendung: nachdem Sie die Prüfdorne in eine beliebige Revolverstation wie ein normaler Werkzeughalter eingespannt haben, können Sie deren Rechtwinkligkeit prüfen, indem Sie die Messuhr entlang der X-Achse der Maschine bewegen.



- Barre de contrôle pour tour revolver CNC avec certificat de contrôle inclus.
- Excentricité / Précision de l'attache, surface de contact et cylindre de contrôle dans 0,003  $\mu$ .
- Emploi: après l'avoir montée dans n'importe quelle station comme un porte-outil normal, vous pouvez vérifier son orthogonalité en déplaçant l'indicateur de mesure sur l'axe X de la machine.



- Контрольная оправка для токарных станков CNC с сертификатом соответствия
- Точность биения, контактная поверхность и контрольный цилиндр в пределах 0,003  $\mu$
- Инструкция к применению: после закрепления на станке, контролировать ортогональность цилиндра, двигая индикатор вдоль оси X.



- 用于数控机床刀具转盘上的检控销, 配备检测报告
- 接口, 接触面和检测的圆柱面的偏心率/精度小于0,003  $\mu$
- 使用方法: 如同常用刀具那样安装在需要检测的刀位上后, 即可通过机轴上滑动千分指标检测其正交性

CONTROL PINS BARRE DI CONTROLLO  
 PRÜFDORNE BARRES DE CONTRÔLE  
 КОНТРОЛЬНЫЕ ЦИЛИНДРЫ 测试棒

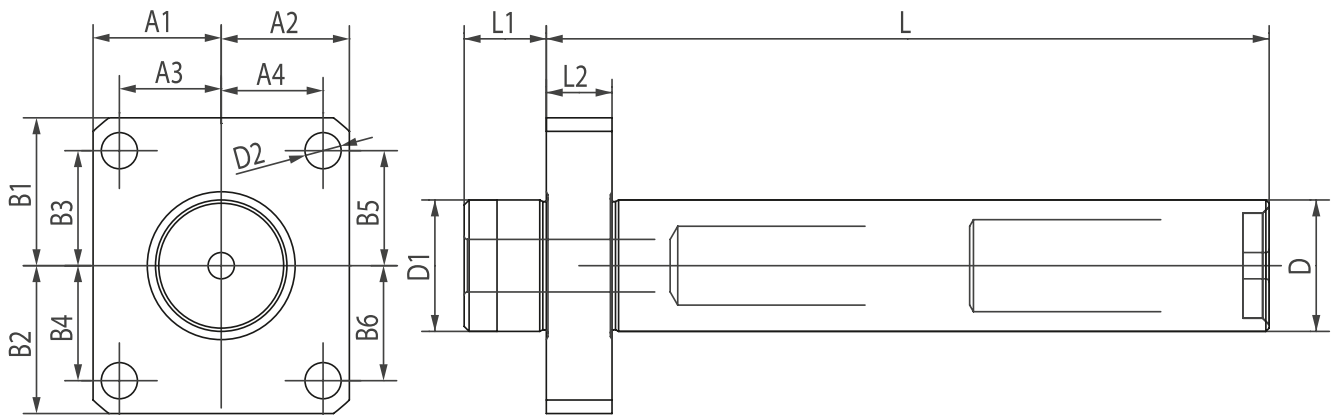

**DMG MORI CTX310ECO-BMT / NZ1500 / NZ2000**

CODE N.	D	L	D1	D2	L1	L2	A1	A2	A3	A4	B1	B2	B3	B4	B5	B6
137-00193	40	220	40	11	25	20	39	39	31	31	45	45	35	35	35	35

**DMG MORI NLX1500-NLX2000 / NLX2500-NLX3000  
 NL2000 (S)MC-2500 (S)MC / NL3000MC (12 STATIONS)**

CODE N.	D	L	D1	D2	L1	L2	A1	A2	A3	A4	B1	B2	B3	B4	B5	B6
137-00194	50	300	60	13	30	25	54	54	42	42	59	59	47	47	47	47

**OKUMA LB2000 EX (M, MY) / LB2500 EX (M)  
 LB3000 EX (M, MY) / LB3000 EX (MW, MYW)**

CODE N.	D	L	D1	D2	L1	L2	A1	A2	A3	A4	B1	B2	B3	B4	B5	B6
137-00195	50	300	60	13	30	25	47,5	47,5	36,5	36,5	50	50	26	39	39	26

**OKUMA LB4000 EX (M, MY)**

CODE N.	D	L	D1	D2	L1	L2	A1	A2	A3	A4	B1	B2	B3	B4	B5	B6
137-00196	50	300	60	13	30	25	50	50	39	39	55	55	40	40	40	40

CONTROL PINS    BARRE DI CONTROLLO  
 PRÜFDORNE    BARRES DE CONTRÔLE  
 КОНТРОЛЬНЫЕ ЦИЛИНДРЫ    测试棒

**DOOSAN LYNX 220LM  
 (BMT45)**

CODE N.	D	L	D1	D2	L1	L2	A1	A2	A3	A4	B1	B2	B3	B4	B5	B6
137-00197	40	220	45	9	25	20	37,5	37,5	29	29	40	40	29	29	29	29

**DOOSAN PUMA230-240M/MS-280LM-1500-2000-2500M/MS/S/SY  
 (BMT55) 2100 SERIE-TT1500-TT1800MS/SY / TL2000-2500LM-MX1600/2100TS / LYNX 300M**

CODE N.	D	L	D1	D2	L1	L2	A1	A2	A3	A4	B1	B2	B3	B4	B5	B6
137-00198	40	220	55	11	30	20	42,5	42,5	32	32	50	50	32	32	32	32

**DOOSAN PUMA300M/MS-V400M-TT2000SY-TT2500SY  
 (BMT65) TT2500MS-2600/3100 SERIE / MX2000ST-MX2500T/ST/LST-VT450/TM  
 INVERTURN 3000M**

CODE N.	D	L	D1	D2	L1	L2	A1	A2	A3	A4	B1	B2	B3	B4	B5	B6
137-00199	50	300	65	13	30	25	47,5	47,5	36,5	36,5	55	55	35	35	35	35

**DOOSAN PUMA400-480M/LM/XLM-VT 750M/TM  
 (BMT75)**

CODE N.	D	L	D1	D2	L1	L2	A1	A2	A3	A4	B1	B2	B3	B4	B5	B6
137-00200	50	300	75	13	30	25	56	56	45	45	57,5	57,5	45	45	45	45

**MAZAK QTS200M**

CODE N.	D	L	D1	D2	L1	L2	A1	A2	A3	A4	B1	B2	B3	B4	B5	B6
137-00201	40	225	68	9	25	25	42	42	34	34	55	75	45	65	45	65

**MAZAK QTS300M**

CODE N.	D	L	D1	D2	L1	L2	A1	A2	A3	A4	B1	B2	B3	B4	B5	B6
137-00202	50	325	80	11	27	25	50	50	36	36	74,5	100	60	85	60	85

**BIGLIA B301/445/470/501(Y-S)/510/545/550/565/650/658  
 1200/446/465/745/765-B750/1250 16 ST BV210/315**

CODE N.	D	L	D1	D2	L1	L2	A1	A2	A3	A4	B1	B2	B3	B4	B5	B6
137-00209	40	220	55	11	30	20	42	42	31,5	31,5	45	45	32,5	32,5	32,5	32,5



SUPPLIED IN ALUMINIUM SUITCASE AND WITH TEST CERTIFICATE.  
 FORNITE IN VALIGETTA IN ALLUMINIO E CON CERTIFICATO DI COLLAUDO.

IM ALUMINIUMKOFFER UND MIT MESSPROTOKOLL GELIEFERT.

FOURNIES DANS UNE MALLETTE EN ALUMINIUM  
 ET AVEC CERTIFICAT DE CONTRÔLE.

ПОСТАВЛЯЮТСЯ В АЛЮМИНИЕВОМ ЯЩИКЕ С  
 СЕРТИФИКАТОМ СООТВЕТСТВИЯ.

提供铝盒包装和检验报告



POSITIONING CONTROL OF THE TOOL CHANGER ARM  
POSITIONSPRÜFUNG DES WERKZEUGWECHSLERS  
ПРИБОР ДЛЯ КОНТРОЛЯ ПОЗИЦИОНИРОВАНИЯ  
ЗАХВАТЧИКА ДЛЯ СМЕНЫ ИНСТРУМЕНТА

CONTROLLO POSIZIONE BRACETTO CAMBIO UTENSILE  
CONTROLE DU POSITIONNEMENT DU BRAS CHANGEUR D'OUTIL  
刀具更换臂的定位装置

CODE	CONE
KIT.PRUEFD-BT30	BT30
KIT.PRUEFD-TC40	TC40
KIT.PRUEFD-TC50	TC50
KIT.PRUEFD-BT40	BT40
KIT.PRUEFD-BT50	BT50
KIT.PRUEFD-H40A	HSK40A
KIT.PRUEFD-H50A	HSK50A
KIT.PRUEFD-H63A	HSK63A
KIT.PRUEFD-H100A	HSK100A
KIT.PRUEFD-C4	C40
KIT.PRUEFD-C5	C50
KIT.PRUEFD-C6	C63

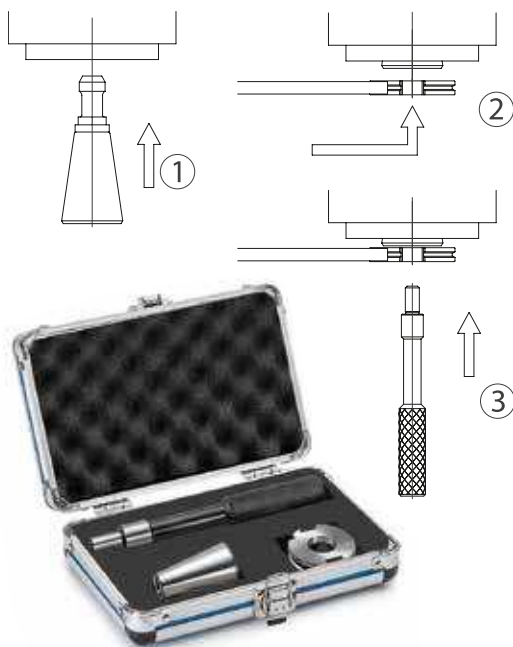

- 1 Après le montage de la tirette, insérez manuellement le cône dans le mandrin de la machine.
- 2 Montez la bride dans le bras changeur d'outil et rapprochez de la machine.
- 3 Après le positionnement, essayez d'insérer la barre de contrôle à double diamètre entre les deux pièces. Ajustez le bras en conséquence jusqu'à ce que vous obtenez la coaxialité parfaite quand la barre entre sans interférences dans les trous de la bride et du cône.



- 1 给接头装上拉钉后，手动将接头插入设备的轴上
- 2 将法兰装到刀具更换臂上并靠近机器设备的轴
- 3 对好位置后，设法将双径控制销插入法兰和接头中。相应调整更换臂的位置至更换臂没有间隙地插入法兰孔和接头直至得到完美的精度

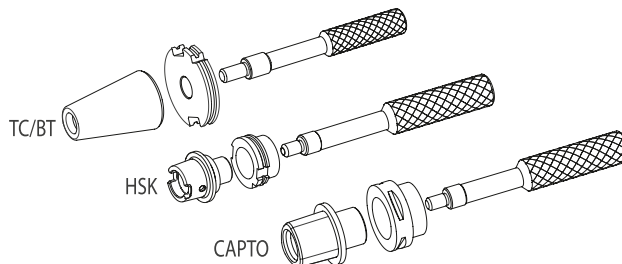

- 1 After assembling the usual pull stud, insert the cone into the spindle manually.
- 2 Set up the flange into the tool changer arm and go closer to the spindle.
- 3 After positioning, try to insert the double-diameter control pin between the two pieces. Adjust the arm accordingly until you get the perfect coaxiality so that the control bar enters the flange and the cone holes with no interferences.



- 1 Inserire manualmente il cono nel mandrino della macchina, dopo aver montato il codolo normalmente usato.
- 2 Montare la flangia nel braccetto cambia utensile ed avvicinarsi al naso macchina.
- 3 Una volta in posizione provare ad inserire la spina di controllo a doppio diametro tra i 2 pezzi. Regolare di conseguenza il braccetto cambia utensile fino a raggiungere la perfetta coassialità quando la spina entra senza interferenze nei fori della flangia e del cono.



- 1 Nach der Montage der üblichen Anzugsbolzen spannen Sie die Aufnahme manuell in die Spindel.
- 2 Spannen Sie den Flansch in den Werkzeugwechsler Arm und gehen Sie näher an der Spindel.
- 3 Nach der Positionierung versuchen Sie, die Doppel-Durchmesser-Prüfdorne zwischen den beiden Stücken einzusetzen. Stellen Sie den Arm entsprechend ein, bis Sie die perfekte Rundlaufgenauigkeit bekommen, wenn die Dorne in die Bohrungen des Flansches und der Aufnahme ohne Übermaß hineingeht.



- 1 После установки штревеля, вставить вручную конус в шпиндель
- 2 Установить фланец в устройство для автоматической смены инструмента
- 3 После установки, вставить двухдиаметровый штифт управления между двумя частями. Отрегулировать устройство для автоматической смены инструмента до идеальной соосности.

KIT-CONTROL PIN + POSITIONING CONTROL  
OF THE TOOL CHANGER ARM  
KIT-PRÜFDORNE + POSITIONSPRÜFUNG  
DES WERKZEUGWECHSLERS  
НАБОР- КОНТРОЛЬНЫЙ ЦИЛИНДР  
+ ЗАХВАТ ДЛЯ ИНСТРУМЕНТАЛЬНОГО МАГАЗИНА

KIT-BARRA DI CONTROLLO + ATTREZZO DI CONTROLLO  
POSIZIONE BRACCETTO CAMBIO UTENSILE  
KIT-BARRE DE CONTRÔLE + CONTRÔLE  
DU POSITIONNEMENT DU BRAS CHANGEUR D'OUTIL  
测试棒和刀具更换臂定位装置的套装

CODE N.	CONO	BARRA
KIT-BT30-CP-PR	BT30	TC30/BT30H200D30BC
KIT-TC40-CP-PR	TC40	TC40H300D40BC
KIT-BT40-CP-PR	BT40	BT40H300D40BC
KIT-HSK63-CP-PR	HSK63	HSK63AH346D40BC
KIT-C63-CP-PR	C63	C63H346D40BC



SUPPLIED IN ALUMINUM SUITCASE AND WITH TEST CERTIFICATE.  
FORNITE IN VALIGETTA IN ALLUMINIO E CON CERTIFICATO DI COLLAUDO.  
IM ALUMINIUMKOFFER UND MIT MESSPROTOKOLL GELIEFERT.  
FOURNIES DANS UNE MALLETTE EN ALUMINIUM ET AVEC CERTIFICAT DE CONTRÔLE.  
ПОСТАВЛЯЮТСЯ В АЛЮМИНИЕВОМ ЯЩИКЕ С СЕРТИФИКАТОМ СООТВЕТСТВИЯ.  
提供铝盒包装和检验报告



## CONTROL PINS

## TECHNICAL FEATURES

### CONE'S TOLERANCE

ACCORDING TO THE CLASS AT3.

### PIN'S TOLERANCE

DIAMETER	RUNOUT ACCURACY	CILINDRICITY
+/-0.05	0.005	0.003

### CONSTRUCTIVE FEATURES

- Manufactured with casehardening Steel
- Casehardened with depth 0,6 - 0,8 mm
- Hardened - Tempered - Black oxidized
- Hardness HRC 58+-2, Strength 800-100 N/mm<sup>2</sup>
- External grinding finish
- Tested 100% with certified measuring instruments



## BARRE DI CONTROLLO

## DATI TECNICI

### TOLLERANZA DEL CONO

PRODOTTI IN CLASSE AT3.

### TOLLERANZE DELLA BARRA

DIAMETRO	COASSIALITÀ	CILINDRICITÀ
+/-0.05	0.005	0.003

### DATI COSTRUTTIVI

- Costruite in acciaio da cementazione certificato e legato
- Cementate con profondità 0,6 - 0,8 mm
- Temperate-rinvenute-brunite
- Durezza HRC 58 +- 2 resistenza 800-1000 N/ mm<sup>2</sup>
- Finitura di rettifica esterna
- Collaudate 100% con strumenti di misura certificati

**PRÜFDORNE****TECHNISCHE DATEN****KEGELSCHAFTTOLERANZEN**

IN KLASSE AT3 ANGEFERTIGT

**PRÜFDORNTOLERANZEN**

DURCHMESSER	RUNDLAUFGENAUIGKEIT	ZYLINDRIZITÄT
+/-0.05	0.005	0.003

**KONSTRUKTIONSDATEN**

- aus Einsatzstahl zertifiziert und legiert angefertigt
- in der Einsatztiefe von 0,6-0,8 mm
- Gehärtet, angelassen, brüniert
- Härte HRC58 +/-2, Festigkeit 800-1000 N/ mm2
- Außgeschliffen
- 100% durch zertifizierte Meßinstrumente geprüft

**BARRES DE CONTROLE****DONNEES TECHNIQUES****TOLERANCE DU CONE**

FABRIQUEES EN CLASSE AT3

**TOLERANCE DE LA BARRE**

DIAMÈTRE	COAXIALITÉ	CYLINDRICITÉ
+/-0.05	0.005	0.003

**ELEMENTS DE CÔNSTRUCTION**

- Produites en acier cémenté certifié et allié au Ni.Cr.Mo.
- Cementeés avec profondeur 0,6 - 0,8 mm
- Trempées - Revenues - Brunies
- Dureté HRC 58 +/- 2 résistance 800-1000 N/ mm2
- Finition de rectification extérieure
- Contrôlées à 100% avec des instruments de mesure certifiés

**КОНТРОЛЬНЫЕ ОПРАВКИ****ТЕХНИЧЕСКОЕ ОПИСАНИЕ****ТОЧНОСТЬ КОНУСА**

СООТВЕТСТВУЕТ КЛАССУ АТ3.

**ТОЧНОСТЬ ЦИЛИНДРА**

DIAMETER	RUNOUT ACCURACY	CILINDRICITY
+/-0.05	0.005	0.003

**КОНСТРУКТИВНЫЕ ОСОБЕННОСТИ**

- Изготовлены из стали с последующей цементацией
- Цементация на глубину 0,6 - 0,8 мм
- Оправки подвергнуты закалке и отпуску. Защитно-декоративное покрытие черного цвета.
- Твердость 58 +/-2 HRC, прочность 800-1000 Н/мм2
- Шлифованная внешняя поверхность
- Каждая оправка испытана на сертифицированном оборудовании

**测试棒****技术特点****锥体的误差**

符合 AT3 级别。

**插销的误差**

DIAMETER	RUNOUT ACCURACY	CILINDRICITY
+/-0.05	0.005	0.003

**结构特点**

- 用表面硬化钢材制造。
- 硬化深度达 0,6 - 0,8 毫米。
- 经过硬化及回火处理。黑色氧化。
- 硬度达 HRC 58 +/-2 强度达 800-1000 N / 平方毫米。
- 外部表面打磨处理。
- 100% 使用经过认证的测量仪器检测。

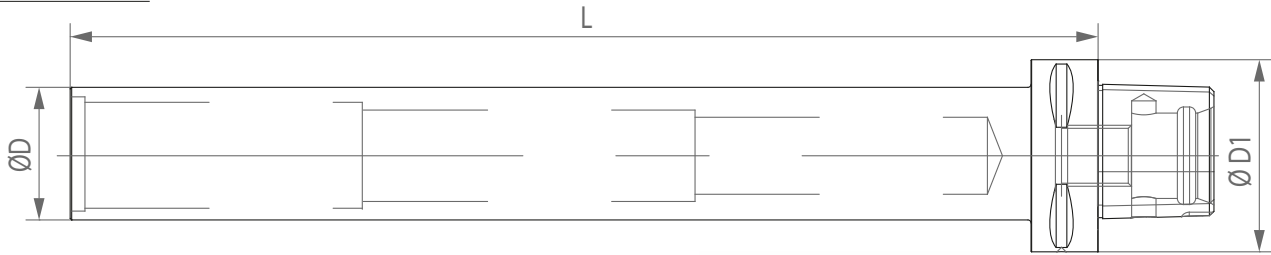

CONTROL PINS    BARRE DI CONTROLLO  
 PRÜFDORNE    BARRES DE CONTROLE  
 КОНТРОЛЬНЫЕ ЦИЛИНДРЫ    测试棒

**DIN 26623-1**

CODE N.	ATTACCO SHANK	D1	D	L
C40H300D35BC	C40	40	35	300
C50H300D40BC	C50	50	40	300
C63H160D35BC	C63	63	35	160
C63H180D40BC	C63	63	40	180
C63H346D40BC	C63	63	40	346
C80H346D40BC	C80	80	40	346



SUPPLIED IN ALUMINUM SUITCASE AND WITH TEST CERTIFICATE.  
 FORNITE IN VALIGETTA IN ALLUMINIO E CON CERTIFICATO DI COLLAUDO.  
 IM ALUMINIUMKOFFER UND MIT MESSPROTOKOLL GELIEFERT.  
 FOURNIES DANS UNE MALLETTE EN ALUMINIUM ET AVEC CERTIFICAT DE CONTRÔLE.  
 ПОСТАВЛЯЮТСЯ В АЛЮМИНИЕВОМ ЯЩИКЕ С СЕРТИФИКАТОМ СООТВЕТСТВИЯ.  
 提供铝盒包装和检验报告

04

CONTROL PINS    BARRE DI CONTROLLO  
 PRÜFDORNE    BARRES DE CONTROLE  
 КОНТРОЛЬНЫЕ ЦИЛИНДРЫ    测试棒

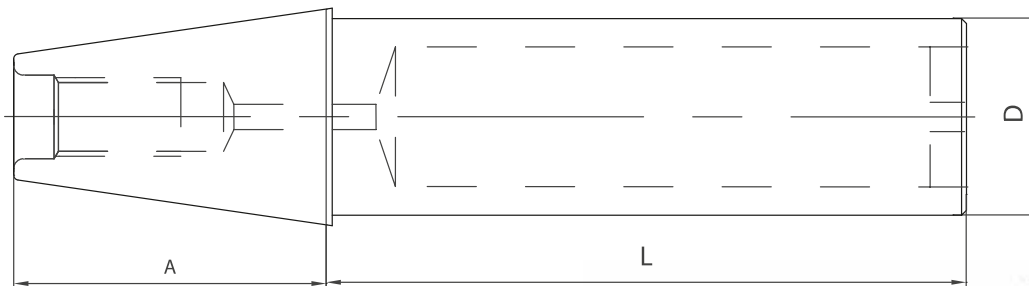
**DIN 69871 A - DIN 2080 - MAS 403BT**

CODE N.	DESCRIPTION	ISO	D	L	A
217-71506	TC30/BT30H200D30BC	30	30	200	48,4
217-71507	BT40H300D40BC	40	40	300	65,4
217-71201	TC40H300D40BC	40	40	300	68,4
217-71202	TC50/BT50H350D50BC	50	50	350	101,75



SUPPLIED IN ALUMINUM SUITCASE AND WITH TEST CERTIFICATE.  
 FORNITE IN VALIGETTA IN ALLUMINIO E CON CERTIFICATO DI COLLAUDO.  
 IM ALUMINIUMKOFFER UND MIT MESSPROTOKOLL GELIEFERT.  
 FOURNIES DANS UNE MALLETTE EN ALUMINIUM ET AVEC CERTIFICAT DE CONTRÔLE.  
 ПОСТАВЛЯЮТСЯ В АЛЮМИНИЕВОМ ЯЩИКЕ С СЕРТИФИКАТОМ СООТВЕТСТВИЯ.  
 提供铝盒包装和检验报告

CONTROL PINS    BARRE DI CONTROLLO  
 PRÜFDORNE    BARRES DE CONTROLE  
 КОНТРОЛЬНЫЕ ЦИЛИНДРЫ    测试棒

**DIN 69871 A - MAS 403BT**

**DOUBLE CONTACT**

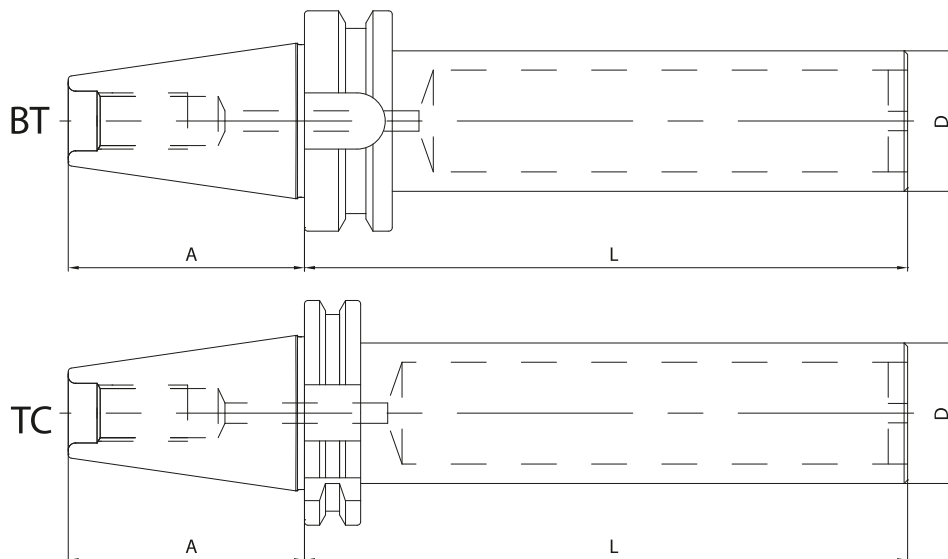

CODE N.	DESCRIPTION	ISO	D	L	A
217-77203	BT30H200D30BCDK	30	30	200	49,4
217-77204	BT40H300D40BCDK	40	40	300	66,4
217-77205	BT50H350D50BCDK	50	50	350	103,3
217-77101	TC40H300D40BCDK	40	40	300	69,4
217-77102	TC50H350D50BCDK	50	50	350	103,25



SUPPLIED IN ALUMINUM SUITCASE AND WITH TEST CERTIFICATE.  
 FORNITE IN VALIGETTA IN ALLUMINIO E CON CERTIFICATO DI COLLAUDO.  
 IM ALUMINIUMKOFFER UND MIT MESSPROTOKOLL GELIEFERT.  
 FOURNIES DANS UNE MALLETTE EN ALUMINIUM ET AVEC CERTIFICAT DE CONTRÔLE.  
 ПОСТАВЛЯЮТСЯ В АЛЮМИНИЕВОМ ЯЩИКЕ С СЕРТИФИКАТОМ СООТВЕТСТВИЯ.  
 提供铝盒包装和检验报告

04



CONTROL PINS    BARRE DI CONTROLLO  
 PRÜFDORNE    BARRES DE CONTROLLE  
 КОНТРОЛЬНЫЕ ЦИЛИНДРЫ    测试棒

## DIN 69893 A

HSK	CODE N.	DESCRIPTION	D	H
32	217-71720	HSK32AH176D25BC	25	176
40	217-71721	HSK40AH180D25BC	25	180
40	217-71702	HSK40AH300D32BC	32	300
50	217-71722	HSK50AH236D32BC	32	236
50	217-71703	HSK50AH300D40BC	40	300
63	217-71735	HSK63H180D40BC	40	180
63	217-71704	HSK63AH380D40BC	40	380
100	217-71736	HSK100H180D40BC	40	180
100	217-71705	HSK100AH350D40BC	40	350
125	217-71729	HSK125AH350D50BC	50	350

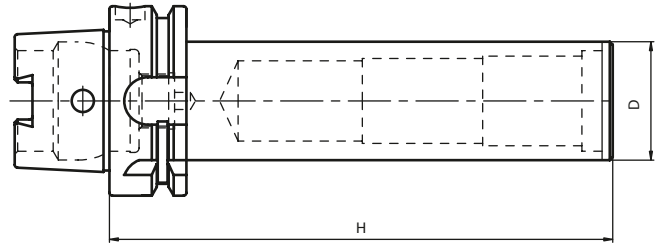

## DIN 69893 C

HSK	CODE N.	DESCRIPTION	D	H
40	217-71909	HSK40CH125D25BC	25	125
50	217-71910	HSK50CH125D32BC	32	125
63	217-71911	HSK63CH160D40BC	40	160
100	217-71913	HSK100CH160D40BC	40	160

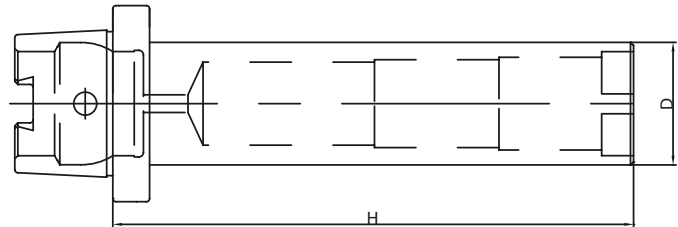

## DIN 69893 B+D

HSK	CODE N.	DESCRIPTION	D	H
63	217-71803	HSK63BH380D40BC	40	380

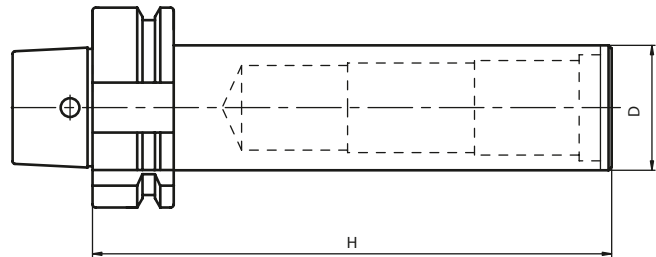

## DIN 69893 F

HSK	CODE N.	DESCRIPTION	D	H
63	217-77402	HSK63FH380D40BC	40	380

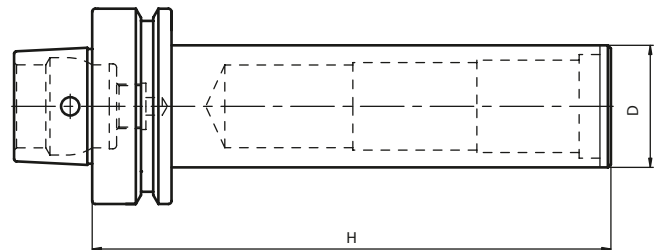

SUPPLIED IN ALUMINUM SUITCASE AND WITH TEST CERTIFICATE.  
 FORNITE IN VALIGETTA IN ALLUMINIO E CON CERTIFICATO DI COLLAUDO.  
 IM ALUMINIUMKOFFER UND MIT MESSPROTOKOLL GELIEFERT.  
 FOURNIES DANS UNE MALLETTE EN ALUMINIUM ET AVEC CERTIFICAT DE CONTRÔLE.  
 ПОСТАВЛЯЮТСЯ В АЛЮМИНИЕВОМ ЯЩИКЕ С СЕРТИФИКАТОМ СООТВЕТСТВИЯ.  
 提供铝盒包装和检验报告

CONTROL PINS BARRE DI CONTROLLO  
 PRÜFDORNE BARRES DE CONTROLLE  
 КОНТРОЛЬНЫЕ ЦИЛИНДРЫ 测试棒

**DIN 69880**

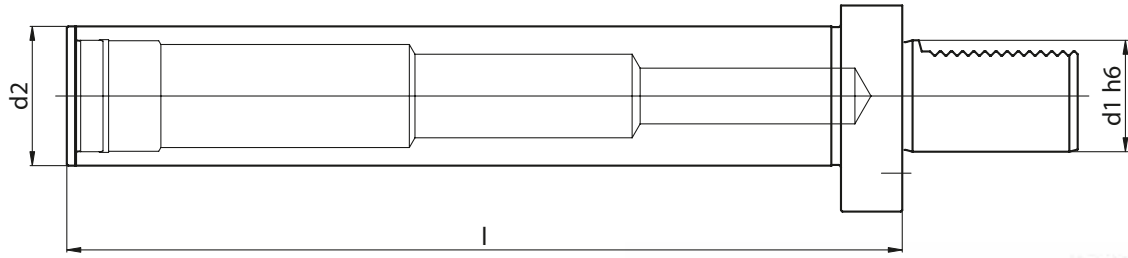

CODE N.	DESCRIPTION	d1	d2	l
118-51601	VDI 16 D25 L200	16	25	200
118-52002	VDI 20 D30 L220	20	30	220
118-52501	VDI 25 D30 L220	25	30	220
118-53002	VDI 30 D40 L230	30	40	230
118-54003	VDI 40 D50 L300	40	50	300
118-55002	VDI 50 D50 L300	50	50	300
118-56002	VDI 60 D60 L300	60	60	300



SUPPLIED IN ALUMINIUM SUITCASE AND WITH TEST CERTIFICATE.  
 FORNITE IN VALIGETTA IN ALLUMINIO E CON CERTIFICATO DI COLLAUDO.  
 IM ALUMINIUMKOFFER UND MIT MESSPROTOKOLL GELIEFERT.  
 FOURNIES DANS UNE MALLETTE EN ALUMINIUM ET AVEC CERTIFICAT DE CONTRÔLE.  
 ПОСТАВЛЯЮТСЯ В АЛЮМИНИЕВОМ ЯЩИКЕ С СЕРТИФИКАТОМ СООТВЕТСТВИЯ.  
 提供铝盒包装和检验报告

